

HAMMER





POWERFUL | DURABLE | RELIABLE | HIGH QUALITY

Mining
Demolition
Rock Breaking
Road Construction

www.thehammer.in

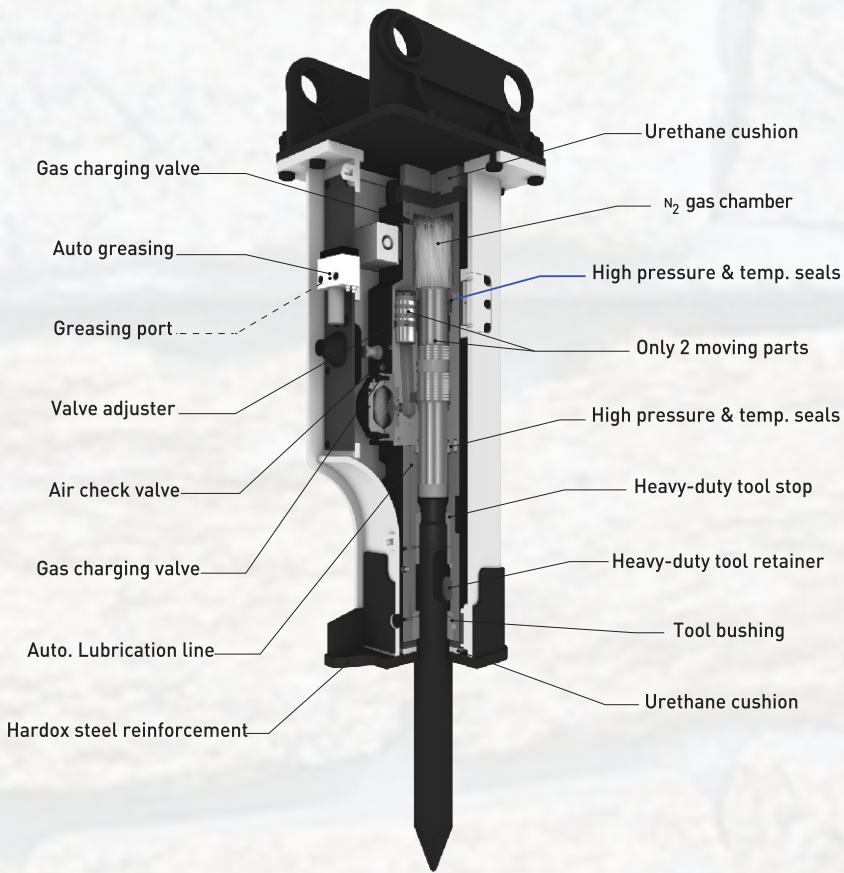
Hydraulic Rock Breakers

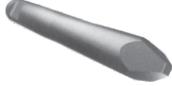
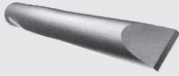

CHISEL TYPE	APPLICATION
	MOIL Concrete Demolition Non-Stratified Rock Secondary Mining of Blocks
	WEDGE All Type of Digging of Stratified Rock
	BLUNT Breaking Blocks or Cutting Blocks to Size
	CONE Universal Tools

FEATURES & BENEFITS :

Proven design for performance and reliability

Hammer Hydraulic Breakers have the most efficient and simple structure with its commitment to the basics. Simple structure enables maintenance cost to be reduced.

HARDOX reinforced housing

The lower part of housing is reinforced by HARDOX for maximum durability.

High power to weight ratio

Due to high quality materials and advanced technology, higher percussive performance to weight ratio is guaranteed.

Impact power mechanism analysis

Keeping dynamical stability, through optimum design using different analysis tools.

Improved vibration dampening

Fully isolated power call with premium quality urethane cushions and wear plates absorb shock and vibration resulting reduced wear.

Auto Lubrication System (Optional)

Enables easy greasing & saves time.

**HAMMER**

High Efficiency

High Performance

Less Weight

Simple Structure

SPECIFICATIONS

ITEM	MODEL	UNIT	HM 80	HM 150	HM 220	HM 220 HD	HM 230 HD	HM 350	HM 450
Operating Weight (Box Type)		Kg	430	870	1811	1870	2011	2780	2990
Drive Oil Pressure		Bar	100 ~ 130	150 ~ 170	160 ~ 180	160 ~ 180	160 ~ 180	170 ~ 190	170 ~ 190
Drive Oil Flow		L/min	40 ~ 70	80 ~ 110	120 ~ 180	120 ~ 180	120 ~ 180	180 ~ 240	200 ~ 260
Chisel Diameter		mm	75	105	140	140	140	155	165
Impact Rate		bpm	550 ~ 950	450 ~ 700	350 ~ 600	350 ~ 600	350 ~ 600	300 ~ 400	280 ~ 370
Applicable Excavator		ton	6 ~ 9	9 ~ 16	18 ~ 25	18 ~ 25	18 ~ 26	28 ~ 35	30 ~ 45

HAMMER

**BREAKING
THROUGH
THE BARRIERS**

CREATIVE ENGINEERING & MINING SOLUTIONS PVT. LTD.

♀ Plot no. 666, Sch. No. 114, Part-II, Anurag Nagar, Indore (M.P.)

Website: www.thehammer.in | E-mail: sales@thehammer.in

